



O-Ring Quality Assurance Standards

Your Technology Specialist

simrit[®]

Simrit O-Ring Quality Assurance Standards

As a world leader in producing the highest quality O-rings available, Simrit strives to provide our customers with comprehensive information about our products for every application.

O-Ring Performance Factors

Many factors other than the gland design, specified O-ring size and elastomer selection can impact the performance of the O-ring in a sealing application. These additional factors have to do with manufacturing, inspecting and storing the O-rings properly and are typically addressed by a good quality assurance program.

Three factors that are of particular importance when dealing with O-rings are:

- Manufacturing Quality Systems
- Surface Quality
- Storage/Shelf Life

Manufacturing Quality Systems

The vast majority of O-rings that Simrit offers are manufactured in facilities that are ISO-9000 and/or QS9000 certified. While these quality systems do not guarantee perfect parts, they do typically justify the associated overhead and the resulting increased cost by ensuring

that the parts are manufactured, inspected and handled in a consistent manner.

Details regarding manufacturing quality systems are available from many other sources and are not specific to O-rings so they will not be presented here.

Surface Quality

The surface quality of an O-ring has a significant impact on its sealing performance. Several industry standards exist that define surface quality imperfections types and set maximum acceptable sizes for each defect type. Several of the more common industry standards are described below.

RMA OR-1

This publication from the Rubber Manufacturers Association describes basic visual quality acceptance criteria for O-rings. Acceptance criteria in this standard are, for the most part, the least stringent of the standards listed here.

MIL-STD-413

This military standard published by the Department of Defense has been adopted by many non-defense-related users of O-rings. All Simrit O-rings are inspected for surface quality per this standard unless otherwise specified.

MIL-STD-413 is more stringent than RMA OR-1.

DIN 3771-4

This publication is the German industrial standard for O-ring surface quality. The standard includes two grade

levels—normal and special. The requirements of this standard are similar to those found in RMA OR-1 and MIL-STD-413.

SAE AS871

This publication from the aerospace side of the Society of Automotive Engineers (SAE) is more stringent than OR-1, MIL-STD-413 and DIN 3771. Standard industrial O-rings will often not meet the requirements of this standard.

SAE AS708

This publication, also from the aerospace side of SAE, defines the requirements for Top Visual Quality O-Rings. This standard should be used only where stringent performance requirements are required, such as safety critical applications.

NOTE: The visual inspection standards are written for imperfection detection with the unaided eye. Magnification is for reference purposes only.

O-Ring Surface Quality Specifications

Surface quality imperfections are typically classified into the following eight types. For each type, the imperfection

is defined and illustrated and then acceptance criteria are listed for several of the standards listed in that section.

BACKRIND

Backrind is usually seen as a longitudinal recess found at the parting line on the ID and/or the OD of the O-ring. The recess is usually shaped like a wide “U” or “W,” and it may cover all or part of the circumference of the O-ring. Backrind is usually caused by thermal expansion of the elastomer over a sharp mold edge or by premature curing of the elastomer.

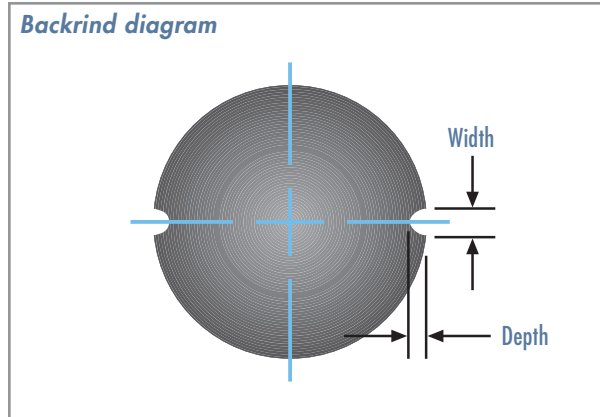

AS568 Series	ISO 3601 CS Code	Units	O-Ring Cross-Section		RMA OR-1		MIL-STD-413		DIN 3771 Normal		DIN 3771 Special	
			Min	Max	Depth	Width	Depth	Width	Depth	Width	Depth	Width
-000	A	mm	0.00	2.53	0.08	0.13	0.00	0.00	0.08	0.18	0.08	0.10
		inch	0.000	0.099	0.003	0.005	0.000	0.000	0.003	0.007	0.003	0.004
-100	B	mm	2.54	3.42	0.08	0.18	0.08	0.13	0.08	0.27	0.08	0.15
		inch	0.100	0.134	0.003	0.007	0.003	0.005	0.003	0.011	0.003	0.006
-200	C	mm	3.43	5.20	0.10	0.20	0.10	0.15	0.10	0.36	0.10	0.20
		inch	0.135	0.204	0.004	0.008	0.004	0.006	0.004	0.014	0.004	0.008
-300	D	mm	5.21	6.83	0.10	0.20	0.10	0.15	0.10	0.53	0.10	0.20
		inch	0.205	0.268	0.004	0.008	0.004	0.006	0.004	0.021	0.004	0.008
-400	E	mm	6.84	n/a	0.13	0.38	0.13	0.25	0.13	0.70	0.13	0.30
		inch	0.269	n/a	0.005	0.015	0.005	0.010	0.005	0.028	0.005	0.012

O-Ring Surface Quality Specifications

EXCESSIVE BUFFING

Excessive buffing is usually seen as flattening on the ID or OD of the O-ring at or near the parting line. Excessive buffing is when sufficient material has been removed at the parting line to cause the cross section of the O-ring to be out of specification. Buffing at the parting line can be detrimental even if the cross-section is still within the specification, as the “buffed” surface may be coarser and may not seal properly. In either case, a flattened or noticeably buffed surface is undesirable and should be cause for reevaluation of the de-flashing process.

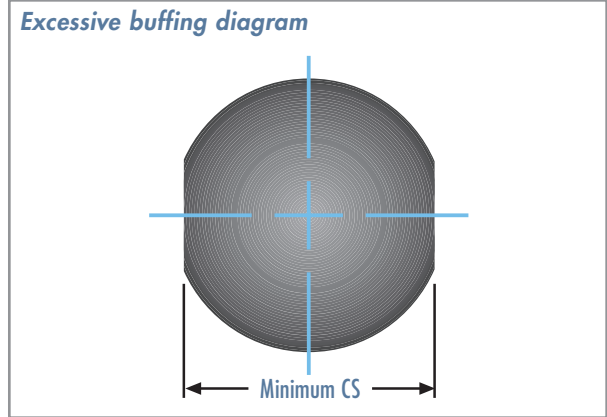

AS568 Series	Units	RMA OR-1 Minimum CS	MIL-STD-413 Minimum CS
-000	mm	1.70	1.70
	inch	0.067	0.067
-100	mm	2.54	2.54
	inch	0.100	0.100
-200	mm	3.43	3.43
	inch	0.135	0.135
-300	mm	5.20	5.20
	inch	0.205	0.205
-400	mm	6.84	6.84
	inch	0.269	0.269

ISO 3601 CS Code	DIN 3771 Normal Minimum CS	DIN 3771 Special Minimum CS
<p>Deviations of the curved cross-section are permissible when the flattened area transitions into the curve of the circular cross-section smoothly and the CS still falls within the permissible tolerances.</p>		

O-Ring Surface Quality Specifications

FOREIGN MATERIAL

Foreign material is defined as any contamination present or any indentation caused by the removal of the contaminant. The size of the protruding contaminant or the remaining indentation is limited as shown in the table below

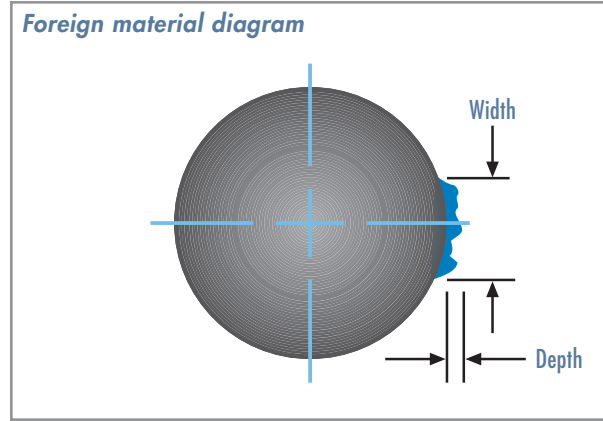

AS568 Series	ISO 3601 CS Code	Units	O-Ring Cross-Section		RMA OR-1		MIL-STD-413		DIN 3771 Normal		DIN 3771 Special	
			Min	Max	Depth	Width	Depth	Width	Depth	Width		
-000	A	mm	0.00	2.53	0.08	0.13	Non-Visible		Not Permitted		Not Permitted	
		inch	0.000	0.099	0.003	0.005	Non-Visible		Not Permitted		Not Permitted	
-100	B	mm	2.54	3.42	0.08	0.20	0.08	0.13	Not Permitted		Not Permitted	
		inch	0.100	0.134	0.003	0.008	0.003	0.005	Not Permitted		Not Permitted	
-200	C	mm	3.43	5.20	0.10	0.25	0.10	0.18	Not Permitted		Not Permitted	
		inch	0.135	0.204	0.004	0.010	0.004	0.007	Not Permitted		Not Permitted	
-300	D	mm	5.21	6.83	0.15	0.38	0.13	0.25	Not Permitted		Not Permitted	
		inch	0.205	0.268	0.006	0.015	0.005	0.010	Not Permitted		Not Permitted	
-400	E	mm	6.84	n/a	0.15	0.51	0.15	0.38	Not Permitted		Not Permitted	
		inch	0.269	n/a	0.006	0.020	0.006	0.015	Not Permitted		Not Permitted	

O-Ring Surface Quality Specifications

PARTING LINE PROJECTION AND EXCESSIVE FLASH

Parting line projection is defined as a continuous ridge of material on the parting line on the ID or the OD of the O-ring. Parting line projection is often a result of mold wear causing enlarged radii at transition from the mold cavity to the flat plane of the tool.

Excessive flash is a thin, film-like feature that extends beyond the parting line projection. Excessive flash is typically a result of improper or inadequate de-flashing.

The maximum allowed height of the parting line projection and excessive flash combined is shown in the table below.

Parting line projection diagram

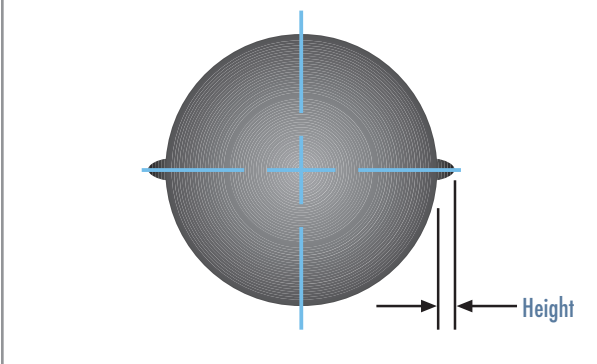

AS568 Series	ISO 3601 CS Code	Units	O-Ring Cross-Section		RMA OR-1 Height	MIL-STD-413 Height	DIN 3771 Normal Height	DIN 3771 Special Height
			Min	Max				
-000	A	mm	0.00	2.53	0.08	0.08	0.10	0.10
		inch	0.000	0.099	0.003	0.003	0.004	0.004
-100	B	mm	2.54	3.42	0.10	0.08	0.12	0.10
		inch	0.100	0.134	0.004	0.003	0.005	0.004
-200	C	mm	3.43	5.20	0.13	0.10	0.14	0.13
		inch	0.135	0.204	0.005	0.004	0.006	0.005
-300	D	mm	5.21	6.83	0.15	0.13	0.16	0.15
		inch	0.205	0.268	0.006	0.005	0.006	0.006
-400	E	mm	6.84	n/a	0.18	0.15	0.18	0.15
		inch	0.269	n/a	0.007	0.006	0.007	0.006

O-Ring Surface Quality Specifications

NON-FILL

Non-fills are typically seen as random and irregular surface indentations. The indentations usually have a coarser texture than the unaffected portions of the O-ring surface. Non-fills are caused by inadequate elastomer to fill the cavity, by imperfect flow of the elastomer within the mold or by air being trapped in the mold. Maximum allowed depths and widths for the indentation are provided below.

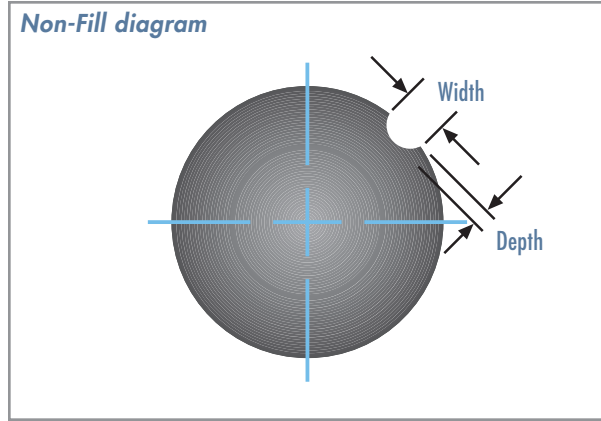

AS568 Series	ISO 3601 CS Code	Units	O-Ring Cross-Section		RMA OR-1		MIL-STD-413		DIN 3771 Normal		DIN 3771 Special	
			Min	Max	Depth	Width	Depth	Width	Depth	Width	Depth	Width
-000	A	mm	0.00	2.53	0.00	0.00	0.00	0.00	0.08	0.60	0.08	0.15
		inch	0.000	0.099	0.000	0.000	0.000	0.000	0.003	0.024	0.003	0.006
-100	B	mm	2.54	3.42	0.08	0.76	0.05	0.25	0.08	0.80	0.08	0.25
		inch	0.100	0.134	0.003	0.030	0.002	0.010	0.003	0.031	0.003	0.010
-200	C	mm	3.43	5.20	0.10	0.76	0.08	0.38	0.10	1.00	0.10	0.40
		inch	0.135	0.204	0.004	0.030	0.003	0.015	0.004	0.039	0.004	0.016
-300	D	mm	5.21	6.83	0.10	1.02	0.08	0.63	0.10	1.30	0.10	0.63
		inch	0.205	0.268	0.004	0.040	0.003	0.025	0.004	0.051	0.004	0.025
-400	E	mm	6.84	n/a	0.10	1.27	0.08	1.02	0.13	1.70	0.13	1.00
		inch	0.269	n/a	0.004	0.050	0.003	0.040	0.005	0.067	0.005	0.039

O-Ring Surface Quality Specifications

MOLD DEPOSIT INDENTATIONS

Mold deposit indentations are typically irregularly shaped, shallow depressions in the O-ring surface. The texture of the indentations is usually rougher than that of the unaffected surface of the O-ring. The indentations are caused by accumulated hardened deposits on the surface of the mold cavities.

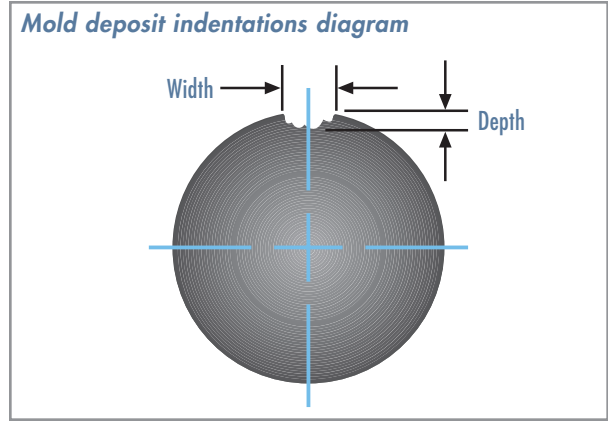

AS568 Series	ISO 3601 CS Code	Units	O-Ring Cross-Section		RMA OR-1		MIL-STD-413		DIN 3771 Normal		DIN 3771 Special	
			Min	Max	Depth	Width	Depth	Width	Depth	Width	Depth	Width
000	A	mm	0.00	2.53	0.08	0.38	0.08	0.25	0.08	0.60	0.08	0.15
		inch	0.000	0.099	0.003	0.015	0.003	0.010	0.003	0.024	0.003	0.006
-100	B	mm	2.54	3.42	0.08	0.51	0.08	0.38	0.08	0.80	0.08	0.25
		inch	0.100	0.134	0.003	0.020	0.003	0.015	0.003	0.031	0.003	0.010
-200	C	mm	3.43	5.20	0.10	0.64	0.10	0.51	0.10	1.00	0.10	0.40
		inch	0.135	0.204	0.004	0.025	0.004	0.020	0.004	0.039	0.004	0.016
-300	D	mm	5.21	6.83	0.13	0.76	0.10	0.63	0.10	1.30	0.10	0.63
		inch	0.205	0.268	0.005	0.030	0.004	0.025	0.004	0.051	0.004	0.025
-400	E	mm	6.84	n/a	0.15	1.02	0.13	0.76	0.13	1.70	0.13	1.00
		inch	0.269	n/a	0.006	0.040	0.005	0.030	0.005	0.067	0.005	0.039

O-Ring Surface Quality Specifications

FLOW MARKS

Flow marks are thread-like recesses in the surface of the O-ring. The recesses are typically curved and have rounded edges. Flow marks are caused by improper flow and premature curing of the elastomer in the mold. Size limits on flow marks are given below.

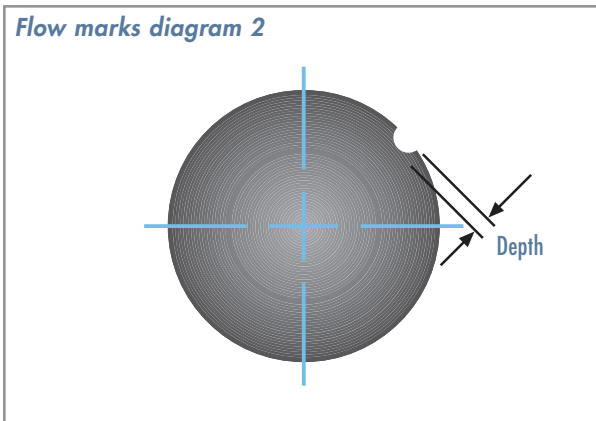
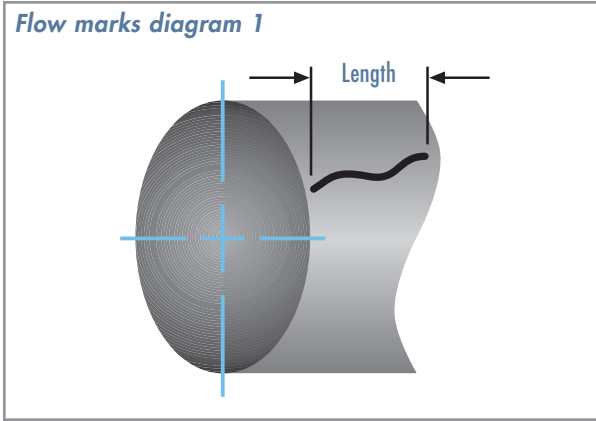

AS568 Series	ISO 3601 CS Code	Units	O-Ring Cross-Section		RMA OR-1 Depth	MIL-STD-413 Depth	MIL-STD-413 Length	DIN 3771 Normal Depth	DIN 3771 Normal Length*	DIN 3771 Special Depth	DIN 3771 Special Length**
			Min	Max							
-000	A	mm	0.00	2.53	no standard available	0.05	1.52	0.08	1.50	0.05	1.50
		inch	0.000	0.099							
-100	B	mm	2.54	3.42	no standard available	0.05	1.52	0.08	1.50	0.05	1.50
		inch	0.100	0.134							
-200	C	mm	3.43	5.20	no standard available	0.05	4.57	0.08	6.50	0.05	5.00
		inch	0.135	0.204							
-300	D	mm	5.21	6.83	no standard available	0.05	4.57	0.08	6.50	0.05	5.00
		inch	0.205	0.268							
-400	E	mm	6.84	n/a	no standard available	0.05	4.57	0.08	6.50	0.05	5.00
		inch	0.269	n/a							

* Maximum length equal to greater of value listed or O-ring ID times 0.05

**Maximum length equal to greater of value listed or O-ring ID times 0.03

O-Ring Surface Quality Specifications

OFF-REGISTER AND/OR MISMATCH

An off-register condition is when the top and bottom halves of the mold are not aligned but are shifted with respect to one another. A mismatch condition is when the top half and the bottom half of the O-ring are different sizes. The maximum length of the off-register or mismatch condition is given below.

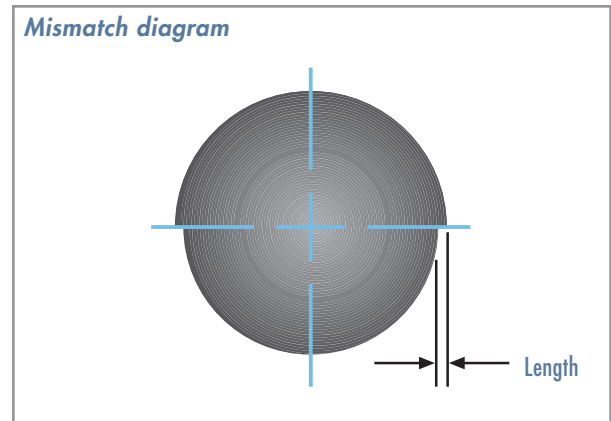
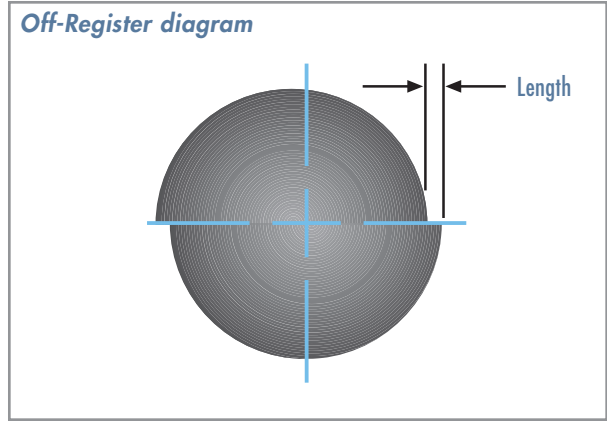

AS568 Series	ISO 3601 CS Code	Units	O-Ring Cross-Section		RMA OR-1 Length	MIL-STD-413 Length	DIN 3771 Normal Length	DIN 3771 Special Length
			Min	Max				
-000	A	mm	0.00	2.53	0.08	0.08	0.08	0.08
		inch	0.000	0.099	0.003	0.003	0.003	0.003
-100	B	mm	2.54	3.42	0.10	0.10	0.10	0.08
		inch	0.100	0.134	0.004	0.004	0.004	0.003
-200	C	mm	3.43	5.20	0.10	0.10	0.13	0.10
		inch	0.135	0.204	0.005	0.005	0.005	0.004
-300	D	mm	5.21	6.83	0.15	0.15	0.15	0.12
		inch	0.205	0.268	0.006	0.006	0.006	0.005
-400	E	mm	6.84	n/a	0.15	0.15	0.15	0.13
		inch	0.269	n/a	0.006	0.006	0.006	0.005

O-Ring Storage Guidelines

O-RING SHELF LIFE

O-rings and other rubber products may undergo changes in physical properties as they age. As such, guidelines exist regarding the maximum recommended shelf life for various elastomer types. The shelf life limits in the table to the right are recommendations from SAE ARP5316.

O-ring shelf life can be maximized by maintaining proper storage conditions for the O-rings. The following list offers storage condition recommendations.

Temperature

The ideal temperature for O-ring storage is 40°F to 80°F (4°C to 27°C). The temperature should not be permitted to exceed 120°F (49°C). The O-rings should be a minimum of 4 feet away from any direct heat source (heater, radiator, vent, etc.).

Humidity

Relative humidity should be maintained at less than 65%. Excessively dry conditions (relative humidity less than ~25%) should also be avoided.

Light

Ultraviolet light can be harmful to certain elastomer types. Whenever possible, O-rings should be stored so that they are not directly exposed to sunlight or high-UV-content artificial light.

Oxygen or Ozone Exposure

Oxygen and ozone can lead to unwanted hardening or chemical attack. O-rings should be stored in airtight containers to limit exposure to these gasses. Electrical equipment that creates ozone should not be placed in areas where O-rings are stored.

Deformation

O-rings should be stored so that they are free from tension, compression or any other deforming force that could lead to permanent shape change.

Elastomer Shelf Life		
Elastomer Type	ASTM Designation	Recommended Shelf Life
Nitrile	NBR	15 years
Hydrogenated Nitrile	HNBR	15 years
Styrene Butadiene	SBR	3 to 5 years
Polyacrylate Acrylic Rubber	ACM	15 years
Ethylene Propylene	EPDM	unlimited
Neoprene/Chloroprene	CR	15 years
Fluorocarbon Elastomer	FKM	unlimited
Silicone	VMQ	unlimited
Fluorosilicone	FVMQ	unlimited
Simriz Perfluoroelastomer	FFKM	unlimited

Simrit Americas

Plymouth, Michigan, USA

Tel: +1 (866) 274 6748

Fax: +1 (734) 354 5500

Simrit Europe

Weinheim, Germany

Tel: +49 (0) 18 05 – 746748

Fax: +49 (0) 18 03 – 746748

Simrit China

Shanghai, China

Tel: +86 (21) 50 36 69 00

Fax: +86 (21) 50 36 63 07

www.simrit.com

