

Simrit Piston Seals Overview

The piston sealing system works with the piston guide bands to create an efficient piston. The piston seal's efficiency affects the ability of the cylinder to hold position, transfer energy, and operate smoothly. The large variety of piston seal designs used in the market today to encompass all conditions makes it difficult to choose a design that will provide the desired piston responsiveness and efficiency. The general goal is maximum sealing with minimum friction, but minimum friction often equals poor piston efficiency and maximum sealing often equals higher friction.

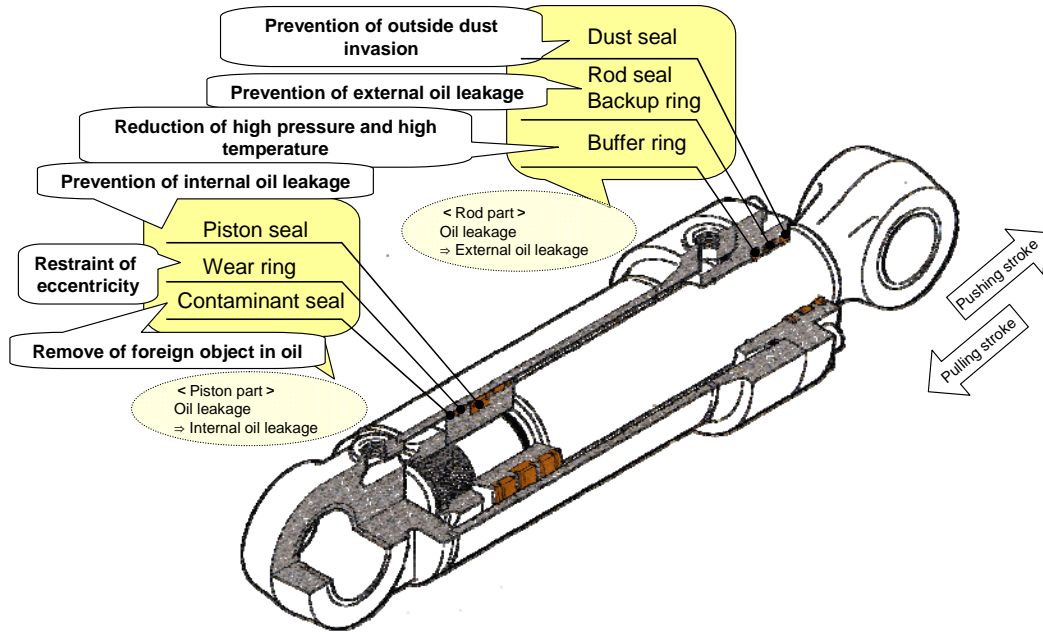

In order to pick the best sealing solution, the cost versus performance target must be examined. In terms of piston seal design the most cost effective solution for the end user is to have a standard piston groove size with the ability to insert various sealing options into this groove to provide the desired piston responsiveness and efficiency. Due to numerous application conditions and various performance targets it becomes complicated to enforce a policy of piston groove standardization.

However, today's improved seal designs and materials allow simplified and more reliable solutions than in the past, and are helping customers to move towards these groove standards. That is why Simrit offers polyurethane, polyamide, and PTFE solutions that can fit into the ISO 7425-1 piston housing groove standards while matching the cost as well as performance objectives of the cylinder.

Benefits of designing Piston Seals to ISO 7425-1

- Standardisation of housing and seal possible
- No need for as many piston seal designs
- Potential cost saving for cylinder / seal
 - Substitution of PTFE sealing element to Polyurethane where possible
 - Substitution of multiple component seal to 2-piece seal where possible

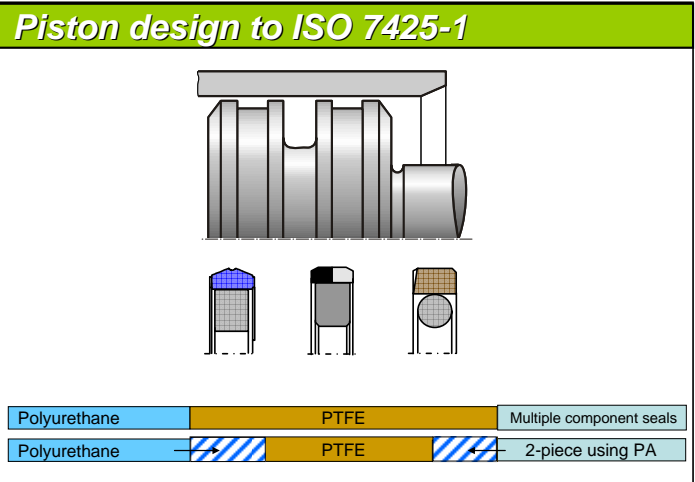

SIMKO 300
(Polyurethane)

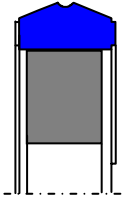

OMK-MR
(PTFE)

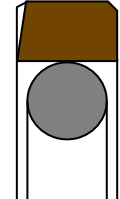

HDP 330
(Polyamide)

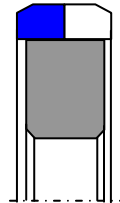

SIMKO 300

- Highest sealing capability
- Highest friction
- Most optimal pricing level
- Simple assembly
- Up to 40 MPa with correct extrusion gap

OMK-MR

- Mid sealing capability
- Low to mid friction (filler dependant)
- For extreme low or high speeds
- For high temperatures
- Up to 40 MPa with correct extrusion gap

HDP 330

- Lowest sealing capability
- Lowest friction
- Rougher surface finishes possible
- Capable of running over ports, etc.
- Used for extreme operating conditions (up to 80 MPa)

